



电子元器件系列(中国.厦门) China.Xiamen  
*www.rf-china.com* RF-Micom co.,Ltd

**Email:sales@rf-china.com**

**Telephone:0086-592-5713956 Fax:5201617**

## [ 2 ] Selection Guide

### 1. Power MOSFET Product Line-up (I<sub>D</sub> = 0.5-20 A)

V <sub>DSS</sub> (V)	12	16	20	30	40	50	60	100	150	180
I <sub>D</sub> (A)										
1							○2SJ360 (0.73) ▲2SJ507 (0.7)	○2SK2963 (0.7) ▲2SK2962 (0.7) ○2SJ508 (1.9) ▲2SJ608 (1.9)	▲2SK3670 (1.7)	▲2SJ1313 (5.0) ▼2SJ338 (5.0) ▲2SK2013 (5.0) ▼2SK2162 (5.0)
2		○2SJ465 (0.71) ○2SK2549 (0.29)		○2SK2964 (0.18) ○2SJ511 (0.45)			○2SK2615 (0.3) ▲2SK2961 (0.27) ○2SK3858 (0.3)			
2.5				N▼TPC6201 (0.095)						
2.7			P▼TPCF8301 (0.11) P▼TPC6105 (0.11) PS▼TPCE8B01 (0.11) P▼TPCF8103 (0.11)							
3			N#TPCF8201 (0.049) NS#TPCF8A01 (0.049) P#TPCF8302 (0.059) P▼TPCF8303 (0.058)					▼2SK2200 (0.35) ▼2SK2201 (0.35)		
3.2				CP▼TPCF8402 (0.077)						
3.4				CP▼TPCP8402 (0.072)						
3.5			P★TPC8302 (0.12)	P★TPC8301 (0.12)						
3.9							P▼TPC6106 (0.075)			
4				CN▼TPCF8402 (0.05)						
4.2				N▼TPCP8201 (0.05) CN▼TPCP8402 (0.05)						
4.5			P#▼TPC6101 (0.06)	P▼TPC6102 (0.06) P★TPC8303 (0.035) CP★TPC8401 (0.035) CP★TPC8402 (0.035) CP★TPC8403 (0.055)						
5		○2SJ439 (0.2) ○2SK2493 (0.1)	★TPC8208 (0.05) ▲TPCS8208 (0.03) N▼TPCS8206 (0.045) N▼TPCS8210 (0.03) P#TPC8305 (0.03) P#TPCS8302 (0.035) P#TPCS8303 (0.021)	○2SJ525 (0.12) ★TPC8004 (0.05) CN▼TPC8402 (0.05) P★TPC8104-H (0.065) ★TPC8209 (0.04) ▼TPCS8209 (0.05)		▲2SK2982 (0.15) ▲2SJ537 (0.19)	▼2SJ669 (0.17) ▼2SJ669 (0.17) ▼2SJ315 (0.25) ▼2SJ377 (0.19) ▼2SJ378 (0.19) ▼2SJ438 (0.19) ▼2SK2229 (0.16) ▼2SK2231 (0.16) N★TPC8206 (0.05)	▼2SK2399 (0.23) ▼2SK2400 (0.23)	▼2SK3205 (0.52)	
5.5	P▼TPC6103 (0.035) PD▼TPCF8401 (0.038)		P▼TPC6104 (0.04)	N★TPC8211 (0.036)						
6	P▼TPCF8101 (0.028)		N#▼TPC6001 (0.03) N#▼TPC6004 (0.024) ★TPC8207 (0.02) ▼TPCS8102 (0.02) ▲TPCS8214 (0.024) ▼TPCS8204 (0.017) P#TPCS8102 (0.02) N#TPCS8212 (0.024) N#TPCS8208 (0.017) P▼TPCF8102 (0.030) ATPCT4201 (0.027)	N▼TPC6002 (0.03) N▼TPC6003 (0.024) ★TPC8203 (0.021) P▼TPCS8101 (0.025) CN★TPC8401 (0.021) CN★TPC8403 (0.033) N#TPC6005 (0.028) P▼TPCF8104 (0.028) NS★TPC8A01 (0.025) ATPCT4201 (0.032) PD▼TPCP8J01 (0.035) (-32 V) N#TPCS8214 (0.0135)						
7				N★TPC8006-H (0.027) P★TPC8106-H (0.04) N▼TPC8004 (0.023)			N★TPC8206 (0.05)			
8				N★TPC8210 (0.015)	P★TPC8110 (0.025)					
8.5				NS★TPC8A01 (0.018)						
9										○2SK2467 (0.83) ○2SJ440 (0.83)
10			P★TPC8115 (0.01)	P★TPC8108 (0.02)				▼2SK2469 (0.125)		○2SJ200 (0.83) ○2SJ440 (0.83) ○2SK1529 (0.83) ○2SK3497 (0.15) ○2SJ618 (0.37)
11	New product series code -----π-MOS III .....π-MOS IV .....π-MOS V .....π-MOS VI .....π-MOS VII L <sup>2</sup> -π-MOS V L <sup>2</sup> -π-MOS VI U-MOS		Note: ( ) = R <sub>DS (ON)</sub> max \$ = 10V drive # = 2.5V drive = = 1.8V drive ¥ = High-speed diode N = N-ch P = p-ch CN = Complementary N-ch CP = Complementary P-ch NS = N-ch + SBD PS = P-ch + SBD PD = P-ch + Driver (load switch)		N★TPC8014 (0.014) P★TPC8108 (0.013) N★TPC8010-H (0.016) P★TPC8113 (0.01) P▼TPCS8104 (0.012) P▼TPCS8105 (0.0135)					
12								▲2SJ380 (0.21)		
13				N[▼TPC8015-H (0.008)] N★TPC8003 (0.007) P★TPC8107 (0.007) P▼TPC8112 (0.006) N★TPC8020-H (0.009)						
14							▲2SJ304 (0.12) ○2SJ312 (0.12)			
15	Package code ○ POWER-MINI ▼ VS-8 ▼ VS-6 ▲ PS-8 ▲ TO-92MOD ▼ POWER-MOLD ▼ DP ★ TPS ★ SOP-8 ○ SOP-8 Lead clamp ▶ SOP Advance		◆ TO-220 (NIS) ○ TO-220SIS ■ TO-220AB ◆ TFP ○ TO-220FL/SM ○ TO-3P (NI) ○ TO-3P (NI) IS ● TO-3P (L) ▼ TSSOP-8 ○ TO-3P (SM) △ STP							
16				N★TPC8013-H (0.0065) N▼TPC8016-H (0.0055) N▼TPC8017-H (0.0066)						
18				N★TPC8A02-H (0.0056)				○2SJ412 (0.21) ◆2SJ618 (0.21)		▲2SK464 (0.09) ◆2SJ620 (0.09) N▶TPC8A006-H (0.067)
20				P▼TPC8114 (0.0045) N▼TPC8018-H (0.0046)		▼2SK2614 (0.046)	▲2SJ349 (0.045) ○2SJ401 (0.045) ▼2SK2762 (0.055)	▲2SK2391 (0.085)		

V <sub>DSS</sub> (V)	200	250	400	450	500	600	700	800	900	1000
I <sub>D</sub> (A)										
0.5					▲2SK2998 (20) ★2SK3302 (18) ◎2SK3471 (18)					
1	◎2SK2992 (3.5)		▼2SK3498 (5.5)	▼2SK3472 (4.6) ★2SK3374 (4.6)		▼2SK3371 (9)			■2SK2733 (9.0) ▼2SK2845 (9) ▼2SK3301 (20)	
1.1		✕IPCS8008 (1.0)								
1.3	✕IPCS8004-H (0.8)									
1.8	★IPCB012-H (0.4)									
2		▼2SJ610 (2.55)		★2SK3543 (2.45) ◎2SK3757 (2.45) ◎2SK3758 (2.45)	★2SK2599 (3.2) ▼2SK3373 (3.2)	★2SK2846 (5.0) ▼2SK2865 (5.0) ★2SK3067 (5.0) ◎2SK3767 (5.0)				
2.5	▼2SJ567 (2.0)								◆2SK2718 (6.4) ◎2SK3566 (6.4) ■2SK3762 (6.4)	
3		▼2SK3462 (1.7)			◆2SK2862 (3.0)			■2SK2603 (3.6) ◎2SK2883 (3.6)	■2SK2608 (4.3) ◆2SK2700 (4.3) □2SK2719 (4.3) ◎2SK3564 (4.3) ■2SK3763 (4.3)	
3.5						★2SK2750 (2.2) ■2SK3085 (2.2) ◎2SK3567 (2.2) ■2SK3760 (2.2)			◎2SK3798 (3.5)	
4		▶IPCA8008-H (0.58)								■2SK1119 (3.8) ◎2SK1930 (3.8)
4.5		▼2SK3342 (1.0)								
5	★2SJ407 (1.0) ★2SK2381 (0.8) ★2SK2835 (0.8) ▼2SK2920 (0.8)	★2SJ512 (1.25)			★2SK2662 (1.5) ■2SK2661 (1.5) ◎2SK2991 (1.5) ▼★2SK3316 (1.8) ▲2SK3466 (1.5) ▼◎2SK3417 (1.8) ◎2SK3563 (1.5) ■2SK3759 (1.5) ▼2SK3863 (1.5) ◎2SK3868 (1.7)	◆2SK2274 (1.7)	◎2SK2604 (2.2) ★2SK2805 (2.2) ◎2SK2884 (2.2)	◎2SK2610 (2.5) ★2SK2717 (2.5) ◎2SK3565 (2.5) ◎2SK3700 (2.5) ◎2SK3742 (2.5)	◎2SK1359 (3.8)	
5.5			◆2SK2679 (1.2) ◎2SK2838 (1.2)							
6						■2SK2544 (1.25) ★2SK2545 (1.25) ◎2SK2602 (1.25) ◎2SK2777 (1.25) ▼★2SK3130 (1.55) ◎2SK3566 (1.25) ■2SK3781 (1.25)				
6.5		★2SJ516 (0.8)								
7								◎2SK2746 (1.7) ◎2SK3633 (1.7)	◎2SK2749 (2.0)	◎2SK1365 (1.8)
7.5		◆2SK2417 (0.5) ■2SK2917 (0.5)				◎2SK3667 (1.0)				
8					■2SK2542 (0.85) ★2SK2543 (0.85) ◎2SK2776 (0.85) ◆2SK3538 (0.85) ◎2SK3561 (0.85) ■2SK3759 (0.85)			◎2SK2606 (1.2)	◎2SK2847 (1.4)	◎2SK1120 (1.8) ◎2SK2613 (1.7)
8.5	★2SK2350 (0.4)	■2SK2914 (0.5)	★2SK2952 (0.55)						◎2SK3017 (1.25)	
9								◎2SK2607 (1.2)	◎2SK2611 (1.4) ◎2SK3473 (1.6) ◎2SK3878 (1.3)	
10			■2SK2841 (0.55) ◎2SK2949 (0.55) ◆2SK3499 (0.55)	★2SK3126 (0.65) ◎2SK3309 (0.65) ★2SK3310 (0.65) ★2SK3407 (0.65) ◎2SK3869 (0.68)	◎2SK2601 (1.0)	◆2SK2843 (0.75) ■2SK2866 (0.75) ◎2SK2889 (0.75) ★2SK2998 (1) ◆2SK3438 (1.0) ◎2SK3437 (1.0) ◎2SK3399 (0.75) ◎2SK3569 (0.75)	◆2SK3265 (1.0) ◎2SK3453 (1.0)			
11	★2SK2965 (0.26)									
12	★2SJ201 (0.625) ★2SK1530 (0.625)				◆2SK2842 (0.52) ◎2SK3068 (0.52) ▼★2SK3313 (0.62) ★2SK3398 (0.52) ◎2SK3568 (0.52)	◎2SK2699 (0.65)				★2SK1489 (1.0)
13		◆2SK2508 (0.25) ◎2SK2598 (0.25)		◆2SK3743 (0.4) ◎2SK3403 (0.4) ◆2SK3544 (0.4)						
14					◎2SK2916 (0.4)	◎2SK3903 (0.44)	New product series code	Package code ◇ POWER-MINI ♣ VS-8 ▼ VS-6 ◆ PS-8 ▲ TO-92MOD ▼ POWER-MOLD ▽ DP L <sup>2</sup> -π-MOS V L <sup>2</sup> -π-MOS VI U-MOS	◆ TO-220 (NIS) ◎ TO-220SIS ■ TO-220AB ◆ TFP ▲ TO-220FL/SM □ TO-3P (N) ◎ TO-3P (N) IS ● TO-3P (L) ★ SOP-8 ◎ SOP-8 Lead clamp ▶ SOP Advance	Note: ( ) = RDS (ON) max \$ = 10V drive # = 2.5V drive * = 1.8V drive ¥ = High-speed diode N = N-ch P = P-ch CN = Complementary N-ch CP = Complementary P-ch NS = N-ch + SBD PS = P-ch + SBD PD = P-ch + Driver (load switch)
15	◆2SK2382 (0.18) ◎2SK2401 (0.18)				◎2SK2698 (0.4) ▼◎2SK3314 (0.48)	◎2SK2953 (0.4)				
16						◎2SK2915 (0.4)				
17					◎2SK3005 (0.31)					
18					◎2SK2917 (0.27)					
19				◎2SK3904 (0.26)						
20		◎2SK2993 (0.105) ◆2SK3388 (0.105) ◆2SK3445 (0.105)			◎2SK2837 (0.27) ◆2SK3117 (0.27)					



### ■ Product Generation Changes by Voltage

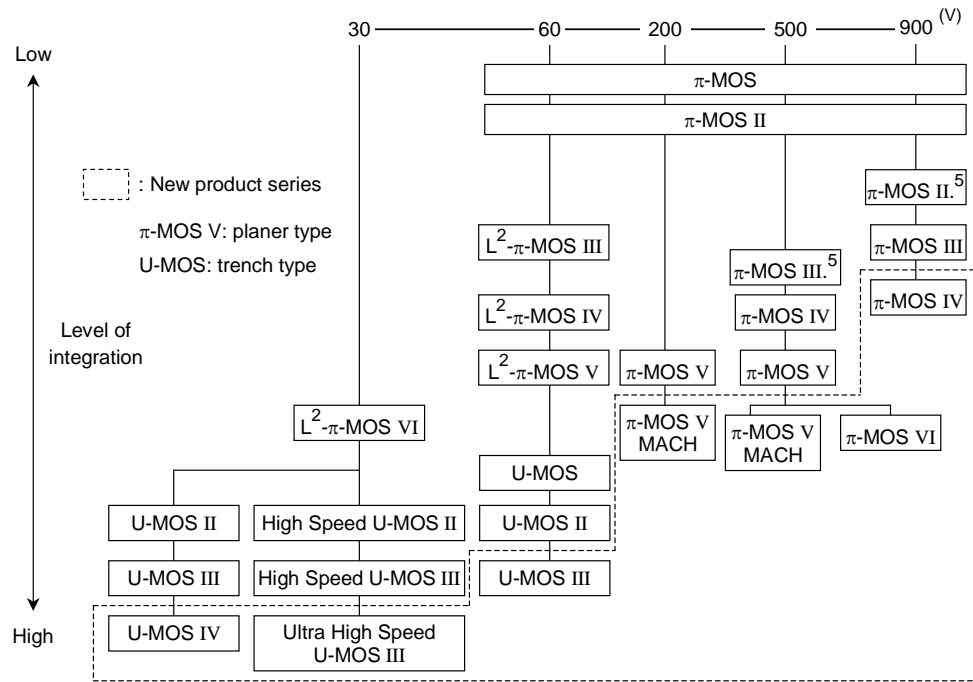

### ■ Product List by Functions

#### ● TPC Series

##### ○ U-MOS IV

- Housed in small thin TOSSP-8 and SOP-8 packages
- Extremely low R<sub>DS (ON)</sub> is achieved employing the buried polysilicon technology.
- This series is suitable for power management use in portable devices.

Part Number	Maximum Ratings		Package	Circuit Configuration	R <sub>DS (ON)</sub> (mΩ) (Max)				
	V <sub>DSS</sub> (V)	I <sub>D</sub> (A)			V <sub>GS</sub> = 10 V	V <sub>GS</sub> = 4.5 V	V <sub>GS</sub> = 4 V	V <sub>GS</sub> = 2.5 V	
TPC8111	-30	-11	SOP-8	Single	12	—	18	—	
TPC8113	-30	-11			10	—	18	—	
TPC8114	-30	-18			4.5	—	6.8	—	
TPCS8104	-30	-11	TSSOP-8		Single	12	—	18	—
TPCS8105	-30	-11				13.2	—	19.5	—
TPCS8303	-20	-5			Dual	—	—	20#	—
TPCS8214	20	6		—		13	13.5	18.5	
TPCP8J01	-32	-6	PS-8	N-ch + NPN	35	49 (4 V)	—	—	
	50	0.1			—	—	—	—	

# V<sub>GS</sub> = 4.5 V

##### ○ U-MOS III

- Extremely low R<sub>DS (ON)</sub>: guarantees 17 mΩ for a dual N-channel MOSFET housed in TSSOP-8
- Single and dual types are available.

Part Number	Maximum Ratings		Package	Circuit Configuration	R <sub>DS (ON)</sub> (mΩ) (Max)				
	V <sub>DSS</sub> (V)	I <sub>D</sub> (A)			V <sub>GS</sub> = 10 V	V <sub>GS</sub> = 4.5 V	V <sub>GS</sub> = 4 V	V <sub>GS</sub> = 2.5 V	V <sub>GS</sub> = 1.8 V
TPC6004	20	6	VS-6	Single	—	—	24	32	—
TPC6005	30	6			—	—	28	35	—
TPC6003	30	6			24	—	32	—	—
TPC6103	-12	-4.5			—	—	35	55	—
TPC6105	-20	-2.7			—	—	110	160	—
TPC6104	-20	-4.5			—	—	40	60	—
TPC6106	-40	-3.9	VS-6	Single	75	120	—	—	—
TPCS8209	20	5	TSSOP-8	Dual	—	30	—	40	—
TPCS8210*	20	5			—	30	—	40	—
TPCS8211	20	6			—	24	—	29	—
TPCS8212*	20	6			—	24	—	29	—
TPCS8204	20	6			—	17	—	22	—
TPCS8208*	20	6			—	17	—	22	—
TPCS8302	-20	-5			—	—	35	60	—

\* Common drain

Part Number	Maximum Ratings		Package	Circuit Configuration	R <sub>DS (ON)</sub> (mΩ) (Max)				
	V <sub>DSS</sub> (V)	I <sub>D</sub> (A)			V <sub>GS</sub> = 10 V	V <sub>GS</sub> = 4.5 V	V <sub>GS</sub> = 4 V	V <sub>GS</sub> = 2.5 V	V <sub>GS</sub> = 1.8 V
TPC8014	30	11	SOP-8	Single	14	—	22	—	—
TPC8109	-30	-10			20	30	—	—	—
TPC8108	-30	-11			13	23	—	—	—
TPC8107	-30	-13			7	15	—	—	—
TPC8207	20	6		Dual	—	20	—	30	—
TPC8208	20	5			—	50	—	70	—
TPC8209	30	5			40	60	—	—	—
TPC8211	30	5.5			36	—	44	—	—
TPC8210	30	8		N-ch + P-ch Dual	15	—	20	—	—
TPC8405	30	6			26	33	—	—	—
	-30	-4.5			33	42	—	—	
TPCF8001	30	6	VS-8	Single	25	—	32	—	—
TPCF8101	-12	-6			—	—	28	40	85
TPCF8103	-20	-5.5			—	—	110	160	300
TPCF8102	-20	-6			—	—	30	41	90
TPCF8104	-30	-6			28	—	38	—	—
TPCF8201	20	3		Dual	—	—	49	66	—
TPCF8301	-20	-2.7			—	—	110	160	300
TPCF8302	-20	-3			—	59	95	—	200 (2 V)
TPCF8303	-20	-3			—	58	87	—	250
TPCF8402	30	2.3		N-ch + P-ch Dual	48	—	77	—	—
	-30	-1.8			72	—	105	—	—
TPCF8A01	20	3.0		N-ch + SBD	—	—	49	66	—
TPCF8B01	-20	-2.7		P-ch + SBD	—	—	110	160	300
TPCP8201	30	4.2		PS-8	N-ch Dual	50	77	—	—
TPCP8401	20	0.1	N-ch/P-ch Load switch		—	3 (4 V)	—	4	—
	-12	-5.5			—	38	—	58	103
TPCP8402	30	2.3	N-ch + P-ch Dual		48	—	77	—	—
	-30	-1.8		72	—	105	—	—	

- U-MOS II
  - Low R<sub>DS (ON)</sub>: guarantees 7 mΩ for an single N-channel MOSFET and 13 mΩ for a single P-channel MOSFET
  - Single and dual types are available.

Part Number	Maximum Ratings		Package	Circuit Configuration	R <sub>DS (ON)</sub> (mΩ) (Max)		
	V <sub>DSS</sub> (V)	I <sub>D</sub> (A)			V <sub>GS</sub> = 10 V	V <sub>GS</sub> = 4 V	V <sub>GS</sub> = 2.5 V
TPC6001	20	6	VS-6	Single	—	30#	45
TPC6002	30	6			30	50#	—
TPC6101	-20	-4.5			—	60#	100
TPC6102	-30	-4.5			60	100#	—
TPC6201	30	2.5		Dual	95	145#	—
TPCS8101	-30	-6	TSSOP-8	Single	25	40	—
TPCS8102	-20	-6			—	20	38
TPCS8205	20	5		Dual	—	30	40
TPC8003	30	13	SOP-8	Single	7	13	—
TPC8203	30	6		Dual	21	32	—
TPC8204	20	6			—	20	30
TPC8206	60	5			50	75	—
TPC8303	-30	-4.5			35	65	—
TPC8305	-20	-5			—	30#	50
TPC8401	30	6			21	32	—
	-30	-4.5			35	65	—
TPC8402	30	6			50	80	—
	-30	-4.5			35	65	—
TPC8403	30	6			33	46	—
	-30	-4.5			55	90	—

# V<sub>GS</sub> = 4.5 V

- Ultra-High Speed U-MOS III
  - Low gate switch charge: reduced by 14% compared to high-speed U-MOS III Series
  - Low R<sub>DS (ON)</sub>: reduced by 34% compared to high-speed U-MOS III Series

Part Number	Maximum Ratings		Package	Circuit Configuration	R <sub>DS (ON)</sub> (mΩ) (Max)		Remarks
	V <sub>DSS</sub> (V)	I <sub>D</sub> (A)			V <sub>GS</sub> = 10 V	V <sub>GS</sub> = 4.5 V	
TPC8017-H	30	15	SOP-8	Single	6.5	9.5	
TPC8018-H	30	18			4.6	6.2	
TPCA8003-H	30	35	SOP Advance		6.6	9.5	
TPCA8004	30	40			4.6	6.2	
TPC8020-H	30	13			9	13	
TPCA8005-H	30	27			9	13	
TPC8A02-H	30	16			5.6	8.5	With built-in SBD
TPC8014-H	40	30			9.5	15	
TPC8016-H	60	25			20	25	

# V<sub>GS</sub> = 4.5 V

- High-Speed U-MOS
  - High-speed switching type: 60% faster ( $t_{off}$ ) than Toshiba's conventional MOSFETs
  - Low gate capacitance: 50% lower than Toshiba's conventional MOSFETs
  - Both N-channel and P-channel types are available.

Part Number	Maximum Ratings		Package	Circuit Configuration	R <sub>DS (ON)</sub> (mΩ) (Max)		Remarks
	V <sub>DSS</sub> (V)	I <sub>D</sub> (A)			V <sub>GS</sub> = 10 V	V <sub>GS</sub> = 4 V	
TPC8006-H	30	7	SOP-8	Single	27	40#	High-Speed U-MOS II
TPC8010-H	30	11			16	27#	High-Speed U-MOS III
TPC8104-H	-30	-5			65	120	High-Speed U-MOS II
TPC8105-H	-30	-7			40	60	High-Speed U-MOS II
TPC8015-H	30	13			8	12#	High-Speed U-MOS III
TPC8016-H	30	15			5.7	7.5#	High-Speed U-MOS III

# V<sub>GS</sub> = 4.5 V

- L<sup>2</sup>-π-MOS VI
 

Low-voltage series suitable for lithium ion secondary battery protection circuits and power management switches

  - Housed in a small thin SOP-8 package that saves board space
  - Two types: V<sub>GS</sub> = 4 V / 2.5 V drive voltage

Part Number	V <sub>DSS</sub> (V)	I <sub>D</sub> (A)	Circuit Configuration	R <sub>DS (ON)</sub> (mΩ) (Max)		
				V <sub>GS</sub> = 10 V	V <sub>GS</sub> = 4 V	V <sub>GS</sub> = 2.5 V
TPC8004	30	5	Single	50	80	—
TPC8001	30	7		20	30	—
TPC8302	-20	-3.5	Dual	—	120	170
TPC8301	-30	-3.5		120	190	—

- 2SK/2SJ Series
  - $\pi$ -MOS V ( $V_{DSS} = 16$  V series)

The  $V_{DSS} = 16$  V series is suitable for use in battery powered portable devices.

- Low voltage: lowers gate drive voltage from 4 to 2.5 V
- Reduced  $R_{DS(ON)}$  to approximately half of that of conventional MOSFETs employing the 0.68  $M_{cell}/cm^2$   $\pi$ -MOS design, thus realizing low loss at low-voltage drive
- Built-in protection zener diode between gate and source
- Both N-channel and P-channel types are available housed in highly popular PW-MINI and PW-MOLD packages.

Part Number	$V_{DSS}$ (V)	$I_D$ (A)	$P_D$ (W)	Package	$R_{DS(ON)}$ ( $\Omega$ )				$R_{DS(ON)}$ ( $\Omega$ )				Qg (nC)
					Typ.	Max	$V_{GS}$ (V)	$I_D$ (A)	Typ.	Max	$V_{GS}$ (V)	$I_D$ (A)	
2SJ465	-16	-2	1.5	PW-MINI	0.54	0.71	-4	-1	0.82	1	-2.5	-0.5	5
2SJ439	-16	-5	20	PW-MOLD	0.14	0.2	-4	-2.5	0.18	0.28	-2.5	-2.5	24
2SK2549	16	2	1.5	PW-MINI	0.21	0.29	4	1	0.29	0.38	2.5	0.5	5
2SK2493	16	5	20	PW-MOLD	0.068	0.1	4	2.5	0.084	0.12	2.5	2.5	23

- U-MOS III
  - Extremely low  $R_{DS(ON)}$  and high ruggedness is realized using the trench technology.

Part Number	Maximum Ratings		Package	$R_{DS(ON)}$ (m $\Omega$ ) (Max)		Qg (nC)
	$V_{DSS}$ (V)	$I_D$ (A)		$V_{GS} = 10$ V	$V_{GS} = 4$ V	
2SK3662	60	35	TO-220NIS	12.5	19	91
2SK3844	60	45	TO-220NIS	5.8	—	196
2SK3845	60	70	TO-3P (N)	5.8	—	196
2SK3842	60	75	TFP	5.8	—	196
2SJ668	-60	-5	PW-MOLD	170	250	15
2SJ669	60	-5	TPS	170	250	15
2SK3864	120	45	TO-220SM	25	—	83

- U-MOS II
  - Employing the trench technology
  - Low  $R_{DS(ON)}$

Part Number	Maximum Ratings			Package	$R_{DS(ON)}$ (m $\Omega$ ) (Max)	
	$V_{DSS}$ (V)	$I_D$ (A)	$P_D$ (W)		$V_{GS} = 10$ V	$V_{GS} = 4$ V
2SK3397	30	70	125	TFP	6.0	—
2SK3389	30	75	125	TFP	5.0	—
2SK3439	30	75	125	TFP	5.0	10
2SK3236	60	35	30	TO-220 (NIS)	20	36
2SK3440	60	50	125	TFP	8.0	—
2SK3441	60	75	125	TFP	5.8	10
2SK3442	100	45	125	TFP	20	—

○ L<sup>2</sup>-π-MOS V

The low R<sub>DS (ON)</sub> series is realized high integration employing the submicron technology.

- R<sub>DS (ON)</sub> is reduced by 15% per unit area compared to L<sup>2</sup>-π-MOS IV.
- Logic-level voltage operation
- Avalanche withstand capability guaranteed
- Built-in protection zener diode between gate and source

Part Number	V <sub>DSS</sub> (V)	I <sub>D</sub> (A)	P <sub>D</sub> (W)	Package	R <sub>DS (ON)</sub> (Ω)				R <sub>DS (ON)</sub> (Ω)				Qg (nC) Typ.
					Typ.	Max	V <sub>GS</sub> (V)	I <sub>D</sub> (A)	Typ.	Max	V <sub>GS</sub> (V)	I <sub>D</sub> (A)	
2SJ511	-30	-2	1.5	PW-MINI	0.32	0.45	-10	-1	0.55	0.76	-4	-1	5.5
2SJ525	-30	-5	1.3	TPS	0.1	0.12	-10	-2.5	0.17	0.2	-4	-2.5	27
2SJ537	-50	-5	0.9	LSTM	0.15	0.19	-10	-2.5	0.29	0.34	-4	-1.3	18
2SJ360	-60	-1	1.5	PW-MINI	0.55	0.73	-10	-0.5	0.86	1.2	-4	-0.5	6.5
2SJ507	-60	-1	0.9	LSTM	0.5	0.7	-10	-0.5	0.72	1.0	-4	-0.5	5.6
2SJ377	-60	-5	20	PW-MOLD	0.16	0.19	-10	-2.5	0.24	0.28	-4	-2.5	22
2SJ378	-60	-5	1.3	TPS	0.16	0.19	-10	-2.5	0.24	0.28	-4	-2.5	22
2SJ438	-60	-5	25	TO-220 (NIS)	0.16	0.19	-10	-2.5	0.24	0.28	-4	-2.5	22
2SJ349	-60	-20	35	TO-220 (NIS)	0.033	0.045	-10	-10	0.05	0.09	-4	-10	90
2SJ401	-60	-20	100	TO-220FL/SM	0.033	0.045	-10	-10	0.05	0.09	-4	-10	90
2SJ334	-60	-30	45	TO-220 (NIS)	0.029	0.038	-10	-15	0.046	0.06	-4	-15	110
2SJ402	-60	-30	100	TO-220FL/SM	0.029	0.038	-10	-15	0.046	0.06	-4	-15	110
2SJ508	-100	-1	1.5	PW-MINI	1.34	1.9	-10	-0.5	1.68	2.5	-4	-0.5	6.3
2SJ380	-100	-12	35	TO-220 (NIS)	0.15	0.21	-10	-6	0.25	0.32	-4	-6	48
2SJ619	-100	-16	75	TFP	0.15	0.21	-10	-6	0.25	0.32	-4	-6	48
2SJ412	-100	-16	60	TO-220FL/SM	0.15	0.21	-10	-6	0.25	0.32	-4	-6	48
2SJ464	-100	-18	45	TO-220 (NIS)	0.064	0.09	-10	-9	0.085	0.12	-4	-9	140
2SJ620	-100	-18	125	TFP	0.064	0.09	-10	-9	0.085	0.12	-4	-9	140
2SK2964	30	2	1.5	PW-MINI	0.13	0.18	10	1	0.18	0.25	4	1	5.8
2SK2844	30	35	40	TO-220AB	0.016	0.02	10	18	0.026	0.035	4	18	40
* 2SK3089	30	40	50	TO-220FL/SM	0.025	0.03	10	20	—	—	—	—	23
* 2SK3090	30	45	60	TO-220FL/SM	0.016	0.02	10	25	—	—	—	—	39
* 2SK3127	30	45	65	TO-220FL/SM	0.0095	0.012	10	25	—	—	—	—	66
* 2SK3506	30	45	100	TO-3P (N)	0.016	0.02	10	25	—	—	—	—	39
* 2SK3125	30	60	50	TO-3P (SM)	0.0053	0.007	10	30	—	—	—	—	130
* 2SK3128	30	60	150	TO-3P (N)	0.0095	0.012	10	30	—	—	—	—	66
2SK2989	50	5	0.9	LSTM	0.12	0.15	10	2.5	0.24	0.33	4	1.3	6.5
2SK2614	50	20	40	DP	0.034	0.046	10	10	0.055	0.08	4	5	25
2SK2507	50	25	30	TO-220 (NIS)	0.034	0.046	10	12	0.058	0.08	4	6	25
2SK2886	50	45	40	TO-220 (NIS)	0.014	0.02	10	25	0.027	0.036	4	25	66
* 2SK3051	50	45	40	TO-220FL/SM	0.024	0.03	10	25	—	—	—	—	36
* 2SK2550	50	45	100	TO-3P (N)	0.024	0.030	10	25	—	—	—	—	36

\*: 10-V drive

Part Number	V <sub>DSS</sub> (V)	I <sub>D</sub> (A)	P <sub>D</sub> (W)	Package	R <sub>DS</sub> (ON) (Ω)				R <sub>DS</sub> (ON) (Ω)				Q <sub>g</sub> (nC) Typ.
					Typ.	Max	V <sub>GS</sub> (V)	I <sub>D</sub> (A)	Typ.	Max	V <sub>GS</sub> (V)	I <sub>D</sub> (A)	
* 2SK2744	50	45	125	TO-3P (N)	0.015	0.02	10	25	—	—	—	—	68
2SK2745	50	50	150	TO-3P (N)	0.007	0.0095	10	25	0.011	0.016	4	25	130
* 2SK2551	50	50	150	TO-3P (N)	0.0072	0.011	10	25	—	—	—	—	130
* 2SK3129	50	60	150	TO-3P (N)	0.0055	0.007	10	30	—	—	—	—	135
2SK2615	60	2	1.5	PW-MINI	0.23	0.3	10	1	0.33	0.44	4	1	6
2SK3658	60	2	1.5	PW-MINI	0.23	0.3	10	1	0.33	0.44	4	1	5
2SK2961	60	2	0.9	LSTM	0.20	0.27	10	1	0.26	0.38	4	1	5.8
2SK2229	60	5	1.3	TPS	0.12	0.16	10	2.5	0.2	0.3	4	1.3	12
2SK2231	60	5	20	PW-MOLD	0.12	0.16	10	2.5	0.2	0.3	4	1.3	12
2SK2782	60	20	40	DP	0.039	0.055	10	10	0.06	0.090	4	5	25
2SK2232	60	25	35	TO-220 (NIS)	0.036	0.046	10	12	0.057	0.08	4	12	38
2SK2311	60	25	40	TO-220FL/SM	0.036	0.046	10	12	0.057	0.08	4	12	38
2SK2385	60	36	40	TO-220 (NIS)	0.022	0.03	10	18	0.04	0.055	4	15	60
2SK2266	60	45	65	TO-220FL/SM	0.022	0.03	10	25	0.04	0.055	4	15	60
2SK2233	60	45	100	TO-3P (N)	0.022	0.03	10	25	0.04	0.055	4	15	60
2SK2312	60	45	45	TO-220 (NIS)	0.013	0.017	10	25	0.019	0.025	4	25	110
2SK2376	60	45	100	TO-220FL/SM	0.013	0.017	10	25	0.019	0.025	4	25	110
* 2SK2398	60	45	100	TO-3P (N)	0.022	0.03	10	25	—	—	—	—	60
2SK2173	60	50	125	TO-3P (N)	0.013	0.017	10	25	0.019	0.025	4	25	110
* 2SK2445	60	50	125	TO-3P (N)	0.014	0.018	10	25	—	—	—	—	110
2SK2267	60	60	150	TO-3P (L)	0.008	0.011	10	30	0.012	0.015	4	30	170
2SK2313	60	60	150	TO-3P (N)	0.008	0.011	10	30	0.012	0.015	4	30	170
2SK2962	100	1	0.9	LSTM	0.5	0.7	10	0.5	0.65	0.95	4	0.5	6.3
2SK2963	100	1	1.5	PW-MINI	0.5	0.7	10	0.5	0.65	0.95	4	0.5	6.3
2SK2200	100	3	1.3	TPS	0.28	0.35	10	2	0.36	0.45	4	2	13.5
2SK2201	100	3	20	PW-MOLD	0.28	0.35	10	2	0.36	0.45	4	2	13.5
2SK2400	100	5	1.3	TPS	0.17	0.23	10	2.5	0.22	0.3	4	2.5	22
2SK2399	100	5	20	PW-MOLD	0.17	0.23	10	2.5	0.22	0.3	4	2.5	22
2SK2391	100	20	35	TO-220 (NIS)	0.066	0.085	10	10	0.09	0.13	4	10	50
2SK2789	100	27	60	TO-220FL/SM	0.066	0.085	10	15	0.09	0.13	4	15	50
2SK2314	100	27	75	TO-220AB	0.066	0.085	10	15	0.09	0.13	4	15	50
2SK2882	150	18	45	TO-220 (NIS)	0.08	0.12	10	9	0.09	0.18	4	9	57

\*: 10-V drive

○  $\pi$ -MOS VII

The latest  $\pi$ -MOS Series is a very high-speed MOSFET employing the submicron technology.

Part Number	Maximum Ratings			Package	$R_{DS(ON)}$ ( $\Omega$ )				Qg (nC) Typ.
	$V_{DSS}$ (V)	$I_D$ (A)	$P_D$ (W)		Typ.	Max	$V_{GS}$ (V)	$I_D$ (A)	
2SK3669	100	10	20	PW-MOLD	0.095	0.125	10	5	8.0
TPCA8006-H	100	18	45	SOP Advance	0.041	0.067	10	9	12.0

○  $\pi$ -MOS V ( $V_{DSS} = 200$  V series)

The low-cost series with  $V_{DSS}$  of 150 to 250 V is ideal for switching frequencies and S-shape correction in monitor applications.

- The submicron technology reduced chip size and achieved favorable cost performance.
- Avalanche withstand capability guaranteed
- Built-in protection zener diode between gate and source
- Product line of  $V_{DSS}$  of 150 V, 200 V and 250 V is ideal for changing capacitance for a resonant circuit.

Part Number	$V_{DSS}$ (V)	$I_D$ (A)	$P_D$ (W)	Package	$R_{DS(ON)}$ ( $\Omega$ )				Qg (nC) Typ.
					Typ.	Max	$V_{GS}$ (V)	$I_D$ (A)	
2SJ567	-200	-2.5	20	PW-MOLD	1.6	2.0	-10	-2.5	10
2SJ407	-200	-5	30	TO-220 (NIS)	0.8	1.0	-10	-2.5	20
2SJ610	-250	-2	20	PW-MOLD	1.85	2.55	-10	-1.0	24
2SJ512	-250	-5	30	TO-220 (NIS)	1.0	1.25	-10	-2.5	22
2SJ516	-250	-6.5	35	TO-220 (NIS)	0.6	0.8	-10	-3	29
2SK3670	150	0.67	0.9	TO-92MOD	1.0	1.7	4	0.5	4.6
2SK2882	150	18	40	TO-220 (NIS)	0.08	0.12	10	9	57
2SK3387	150	18	100	TFP	0.08	0.12	10	9	57
2SK2992	200	1	1.5	PW-MINI	2.2	3.5	10	0.5	3
TPCS8004	200	1.3	1.1	TSSOP-8	0.56	0.8	10	0.6	12
TPC8012-H	200	1.8	1.9	SOP-8	0.28	0.4	10	0.9	11
2SK2381	200	5	25	TO-220 (NIS)	0.56	0.8	10	2.5	10
2SK2835	200	5	1.3	TPS	0.56	0.8	10	2.5	10
2SK2920	200	5	20	PW-MOLD	0.56	0.8	10	2.5	10
2SK2350	200	8.5	30	TO-220 (NIS)	0.26	0.4	10	5	17
2SK2965	200	11	35	TO-220 (NIS)	0.15	0.26	10	5.5	30
2SK2382	200	15	45	TO-220 (NIS)	0.13	0.18	10	10	40
2SK2401	200	15	75	TO-220FL/SM	0.13	0.18	10	10	40
2SK3176	200	30	150	TO-3P (N)	0.038	0.052	10	15	125
TPCS8006	250	1.1	1.5	TSSOP-8	0.8	1.0	10	0.5	11
2SK3462	250	3	20	PW-MOLD	1.2	1.7	10	1.5	12
2SK3342	250	4.5	20	PW-MOLD	0.8	1.0	10	2.5	10
2SK2417	250	7.5	30	TO-220 (NIS)	0.42	0.5	10	3.5	20
2SK2914	250	7.5	50	TO-220AB	0.42	0.5	10	3.5	20
2SK2508	250	13	45	TO-220 (NIS)	0.18	0.25	10	6.5	40

Part Number	V <sub>DSS</sub> (V)	I <sub>D</sub> (A)	P <sub>D</sub> (W)	Package	R <sub>DS (ON)</sub> (Ω)				Q <sub>g</sub> (nC) Typ.
					Typ.	Max	V <sub>GS</sub> (V)	I <sub>D</sub> (A)	
2SK2598	250	13	60	TO-220FL/SM	0.18	0.25	10	6.5	40
2SK2993	250	20	100	TO-220FL/SM	0.082	0.105	10	10	100
2SK3388	250	20	125	TFP	0.082	0.105	10	10	100
2SK2995	250	30	90	TO-3P (N) IS	0.048	0.068	10	15	132
2SK2967	250	30	150	TO-3P (N)	0.048	0.068	10	15	132

- π-MOS MACH, High-Speed π-MOS, Series  
High-speed switching series

Part Number	Maximum Ratings			Package	R <sub>DS (ON)</sub> (Ω)			Q <sub>g</sub> (nC) Typ.	Conventional MOSFET
	V <sub>DSS</sub> (V)	I <sub>D</sub> (A)	P <sub>D</sub> (W)		Max	V <sub>GS</sub> (V)	I <sub>D</sub> (A)		
2SK3443	150	30	125	TFP	0.055	10	15	45	—
2SK3444	200	25	125	TFP	0.082	10	12.5	44	—
2SK3625	200	25	100	TO-220FL/SM	0.082	10	12.5	44	—
2SK3445	250	20	125	TFP	0.105	10	10	45	—
2SK3310	450	10	40	TO-220 (NIS)	0.65	10	5	23	2SK3126
2SK3309	450	10	65	TO-220FL/SM	0.65	10	5	23	—
2SK3403	450	13	100	TO-220FL/SM	0.4	10	6.5	34	—
2SK3437	600	10	80	TO-220FL/SM	1	10	5	30	2SK2996
2SK3399	600	10	100	TO-220FL/SM	0.75	10	5	35	2SK2866
2SK3633	800	7	150	TO-3P (N)	1.7	10	3.5	35	2SK2746
2SK3473	900	9	150	TO-3P (N)	1.6	10	4.5	38	2SK2611

- π-MOS MACH, High-Speed Diode (HSD), Series

Part Number	Maximum Ratings			Package	R <sub>DS (ON)</sub> (Ω)			t <sub>rr</sub> (nC) Typ.	Conventional MOSFET
	V <sub>DSS</sub> (V)	I <sub>D</sub> (A)	P <sub>D</sub> (W)		Max	V <sub>GS</sub> (V)	I <sub>D</sub> (A)		
2SK3417	500	5	50	TO-220FL/SM	1.8	10	2.5	60	2SK2662
2SK3316	500	5	35	TO-220 (NIS)	1.8	10	2.5	60	2SK2662
2SK3868	500	5	35	TO-220SIS	1.7	10	2.5	16	2SK3563
2SK3313	500	12	45	TO-220 (NIS)	0.62	10	5	100	2SK2842
2SK3314	500	15	150	TO-3P (N)	0.48	10	7	120	2SK2698
2SK3131	500	50	250	TO-3PL	0.11	10	25	140	2SK3132
2SK3130	600	6	40	TO-220 (NIS)	1.5	10	3	60	2SK2545

○  $\pi$ -MOS VI

The latest  $V_{DSS}$  of 500 to 600 V series is faster speed and lower cost than those of  $\pi$ -MOS V.

- Available with a new TO-220SIS package

Part Number	$V_{DSS}$ (V)	$I_D$ (A)	$P_D$ (W)	Package	$R_{DS(ON)}$ ( $\Omega$ )				Qg (nC) Typ.
					Typ.	Max	$V_{GS}$ (V)	$I_D$ (A)	
2SK3766	450	2	30	TO-220SIS	1.9	2.45	10	1	8
2SK3757	450	2	30	TO-220SIS	1.9	2.45	10	1	9
2SK3869	450	10	40	TO-220SIS	0.55	0.68	10	5	28
2SK3904	450	19	150	TO-3P (N)	0.2	0.26	10	9.5	62
2SK3563	500	5	35	TO-220SIS	1.35	1.5	10	2.5	16
2SK3863	500	5	40	DP	1.35	1.5	10	2.5	16
2SK3868	500	5	40	TO-220SIS	1.3	1.7	10	2.5	16
2SK3758	500	5	58	TO-220AB	1.35	1.5	10	2.5	16
2SK3561	500	8	40	TO-220SIS	0.75	0.85	10	4	28
2SK3759	500	8	74	TO-220AB	0.75	0.85	10	4	28
2SK3568	500	12	40	TO-220SIS	0.4	0.52	10	6	42
2SK3905	500	17	150	TO-3P (N)	0.25	0.31	10	8.5	62
2SK3767	600	2	25	TO-220SIS	3.3	4.5	10	1	9
2SK3567	600	3.5	35	TO-220SIS	1.7	2.2	10	1.8	16
2SK3760	600	3.5	60	TO-220AB	1.7	2.2	10	1.8	16
2SK3562	600	6	40	TO-220SIS	0.9	1.25	10	3	28
2SK3761	600	6	74	TO-220AB	0.9	1.25	10	3	28
2SK3667	600	7.5	45	TO-220SIS	0.65	1.0	10	4	33
2SK3569	600	10	45	TO-220SIS	0.54	0.75	10	5	42
2SK3903	600	14	150	TO-3P (N)	0.32	0.44	10	7	6.2

○  $\pi$ -MOS V ( $V_{DSS} = 500$  V)

The high-performance, high-ruggedness and low-cost with  $V_{DSS}$  of 500 V series is ideal use for 100-V AC input switching power supplies.

- Low-power drive and high-speed type
- $V_{GSS} = \pm 30$  V guaranteed in all product lines
- Avalanche withstand capability guaranteed
- Built-in protection zener diode between gate and source

Part Number	$V_{DSS}$ (V)	$I_D$ (A)	$P_D$ (W)	Package	$R_{DS(ON)}$ ( $\Omega$ )				Qg (nC) Typ.
					Typ.	Max	$V_{GS}$ (V)	$I_D$ (A)	
2SK3498	400	1	20	PW-MOLD	4.2	5.5	10	0.5	5.7
2SK2679	400	5.5	35	TO-220 (NIS)	0.84	1.2	10	3	17
2SK2838	400	5.5	40	TO-220FL/SM	0.84	1.2	10	3	17
2SK2952	400	8.5	40	TO-220 (NIS)	0.4	0.55	10	5	34
2SK2841	400	10	80	TO-220AB	0.4	0.55	10	5	34
2SK2949	400	10	65	TO-220FL/SM	0.4	0.55	10	5	34

Part Number	V <sub>DSS</sub> (V)	I <sub>D</sub> (A)	P <sub>D</sub> (W)	Package	R <sub>DS(ON)</sub> (Ω)				Q <sub>g</sub> (nC) Typ.
					Typ.	Max	V <sub>GS</sub> (V)	I <sub>D</sub> (A)	
2SK3499	400	10	80	TFP	0.4	0.55	10	5	34
2SK3472	450	1	20	PW-MOLD	4	4.6	10	0.5	5
2SK3543	450	2	30	TO-220NIS	1.9	2.45	10	1	9
2SK3126	450	10	40	TO-220 (NIS)	0.48	0.65	10	5	35
2SK3309	450	10	65	TO-220FL/SM	0.48	0.65	10	5	35
2SK2998	500	0.5	0.9	TO-92MOD	10	18	10	0.25	3.8
2SK3302	500	0.5	1.3	TPS	10	18	10	0.25	3.8
2SK3471	500	0.5	1.5	PW-MINI	10	18	10	0.25	3.8
2SK2599	500	2	1.3	TPS	2.9	3.2	10	1	9
2SK2862	500	3	25	TO-220 (NIS)	2.9	3.2	10	1	9
2SK2661	500	5	75	TO-220AB	1.35	1.5	10	2.5	17
2SK2662	500	5	35	TO-220 (NIS)	1.35	1.5	10	2.5	17
2SK2991	500	5	50	TO-220FL/SM	1.35	1.5	10	2.5	17
2SK3466	500	5	50	TFP	1.35	1.5	10	2.5	17
2SK2542	500	8	80	TO-220AB	0.75	0.85	10	4	30
2SK2543	500	8	40	TO-220 (NIS)	0.75	0.85	10	4	30
2SK2776	500	8	65	TO-220FL/SM	0.75	0.85	10	4	30
2SK3538	500	8	65	TFP	0.75	0.85	10	4	30
2SK2601	500	10	125	TO-3P (N)	0.75	1.0	10	5	30
2SK2842	500	12	40	TO-220 (NIS)	0.4	0.52	10	6	45
2SK3068	500	12	100	TO-220FL/SM	0.4	0.52	10	6	45
2SK3398	500	12	100	TFP	0.4	0.52	10	6	45
2SK2916	500	14	80	TO-3P (N) IS	0.35	0.4	10	7	58
2SK2698	500	15	150	TO-3P (N)	0.35	0.4	10	7	58
2SK2917	500	18	90	TO-3P (N) IS	0.21	0.27	10	10	80
2SK3310	450	10	40	TO-220 (NIS)	0.48	0.65	10	5	23
2SK3407	450	10	40	TO-220 (NIS)	0.48	0.65	10	5	35
2SK3743	450	13	45	TO-220 (NIS)	0.29	0.4	10	6	34
2SK3403	450	13	100	TO-220FL/SM	0.29	0.4	10	6	34
2SK2837	500	20	150	TO-3P (N)	0.21	0.27	10	10	80
2SK3117	500	20	150	TO-3P (SM)	0.21	0.27	10	10	80
2SK3132	500	50	250	TO-3P (L)	0.07	0.095	10	25	280
2SK3371	600	1	20	PW-MOLD	6.4	9.0	10	0.5	9
2SK2846	600	2	1.3	TPS	4.2	5.0	10	1	9
2SK2865	600	2	20	PW-MOLD	4.2	5.0	10	1	9
2SK3067	600	2	25	TO-220 (NIS)	4.2	5.0	10	1	9
2SK2750	600	3.5	35	TO-220 (NIS)	1.7	2.2	10	1.8	20
2SK3085	600	3.5	75	TO-220AB	1.7	2.2	10	1.8	20
2SK2545	600	6	40	TO-220 (NIS)	0.9	1.25	10	3	30
2SK2777	600	6	65	TO-220FL/SM	0.9	1.25	10	3	30
2SK2544	600	6	80	TO-220AB	0.9	1.25	10	3	30
2SK2602	600	6	125	TO-3P (N)	0.9	1.25	10	3	30

Part Number	V <sub>DSS</sub> (V)	I <sub>D</sub> (A)	P <sub>D</sub> (W)	Package	R <sub>DS (ON)</sub> (Ω)				Q <sub>g</sub> (nC) Typ.
					Typ.	Max	V <sub>GS</sub> (V)	I <sub>D</sub> (A)	
2SK2843	600	10	45	TO-220 (NIS)	0.54	0.75	10	5	45
2SK2889	600	10	100	TO-220FL/SM	0.54	0.75	10	5	45
2SK2866	600	10	125	TO-220AB	0.54	0.75	10	5	45
2SK2996	600	10	45	TO-220 (NIS)	0.74	1.0	10	5	38
2SK3438	600	10	125	TFP	0.74	1.0	10	5	28
2SK2699	600	12	150	TO-3P (N)	0.5	0.65	10	6	58
2SK2953	600	15	90	TO-3P (N) IS	0.31	0.4	10	8	80
2SK2915	600	16	150	TO-3P (N)	0.31	0.4	10	8	80
2SK3265	700	10	45	TO-220 (NIS)	—	1.0	10	5	—

○ π-MOS IV

The latest V<sub>DSS</sub> of 900 V series is higher integration than π-MOS III.

- Available with a new TO-220SIS package

Part Number	V <sub>DSS</sub> (V)	I <sub>D</sub> (A)	P <sub>D</sub> (W)	Package	R <sub>DS (ON)</sub> (Ω)				Q <sub>g</sub> (nC) Typ.
					Typ.	Max	V <sub>GS</sub> (V)	I <sub>D</sub> (A)	
2SK3566	900	2.5	40	TO-220SIS	5.6	6.4	10	1.5	12
2SK3762	900	2.5	62	TO-220AB	5.6	6.4	10	1.5	12
2SK3564	900	3	40	TO-220SIS	3.7	4.3	10	1.5	17
2SK3763	900	3	69	TO-220AB	3.7	4.3	10	1.5	17
2SK3798	900	4	40	TO-220SIS	2.5	3.5	10	2	26
2SK3565	900	5	45	TO-220SIS	2.0	2.5	10	3	28
2SK3742	900	5	45	TO-220SIS	2.2	2.5	10	2.5	28
2SK3700	900	5	150	TO-3P (N)	2.2	2.5	10	2.5	28
2SK3473	900	9	150	TO-3P (N)	1.3	1.6	10	4.5	38
2SK3878	900	9	150	TO-3P (N)	1.1	1.3	10	4	60

- $\pi$ -MOS III ( $V_{DSS} = 900$  V series)

The latest  $V_{DSS}$  of 900 V series combines high performance and low cost, and features higher cell density than the  $\pi$ -MOS II.5 Series. This series is ideal use for 200-V AC input switching power supplies.

- The submicron technology also contributed to achieve favorable cost performance.
- $V_{GSS} = \pm 30$  V guaranteed in all product lines
- Avalanche withstand capability guaranteed
- Built-in protection zener diode between gate and source

Part Number	$V_{DSS}$ (V)	$I_D$ (A)	$P_D$ (W)	Package	$R_{DS(ON)}$ ( $\Omega$ )				Qg (nC) Typ.
					Typ.	Max	$V_{GS}$ (V)	$I_D$ (A)	
2SK3453	700	10	80	TO-3P (N) IS	0.72	1.0	10	5	53
2SK2603	800	3	100	TO-220AB	3.0	3.6	10	1.5	25
2SK2883	800	3	75	TO-220FL/SM	3.0	3.6	10	1.5	25
2SK2605	800	5	45	TO-220 (NIS)	1.9	2.2	10	3.0	34
2SK2884	800	5	100	TO-220FL/SM	1.9	2.2	10	3.0	34
2SK2604	800	5	125	TO-3P (N)	1.9	2.2	10	3.0	34
2SK2746	800	7	150	TO-3P (N)	1.3	1.7	10	3.5	55
2SK2606	800	8	85	TO-3P (N) IS	1.0	1.2	10	4.0	68
2SK2607	800	9	150	TO-3P (N)	1.0	1.2	10	4.0	68
2SK3301	900	1	20	PW-MOLD	15	20	10	0.5	15
2SK2845	900	1	40	DP	8.0	9.0	10	0.5	15
2SK2733	900	1	60	TO-220AB	8.0	9.0	10	0.5	15
2SK2718	900	2.5	40	TO-220 (NIS)	5.6	6.4	10	1.5	21
2SK2608	900	3	100	TO-220AB	3.7	4.3	10	1.5	25
2SK2700	900	3	40	TO-220 (NIS)	3.7	4.3	10	1.5	25
2SK2719	900	3	125	TO-3P (N)	3.7	4.3	10	1.5	25
2SK2717	900	5	45	TO-220 (NIS)	2.3	2.5	10	3.0	45
2SK2610	900	5	150	TO-3P (N)	2.3	2.5	10	3.0	45
2SK2749	900	7	150	TO-3P (N)	1.6	2.0	10	3.5	55
2SK2847	900	8	85	TO-3P (N) IS	1.1	1.4	10	4.0	58
2SK3017	900	8.5	90	TO-3P (N) IS	1.05	1.25	10	4.0	70
2SK2611	900	9	150	TO-3P (N)	1.2	1.4	10	4.0	58
2SK2968	900	10	150	TO-3P (N)	1.05	1.25	10	4.0	70
2SK2613	1000	8	150	TO-3P (N)	1.3	1.7	10	4.0	65

○  $\pi$ -MOS

This is the well-proven standard  $\pi$ -MOS series.

Part Number	V <sub>DSS</sub> (V)	I <sub>D</sub> (A)	P <sub>D</sub> (W)	Package	R <sub>DS (ON)</sub> ( $\Omega$ )				R <sub>DS (ON)</sub> ( $\Omega$ )				Q <sub>g</sub> (nC)
					Typ.	Max	V <sub>GS</sub> (V)	I <sub>D</sub> (A)	Typ.	Max	V <sub>GS</sub> (V)	I <sub>D</sub> (A)	
2SJ315	-60	-5	20	PW-MOLD	0.21	0.25	-10	-2.5	0.31	0.4	-4	-2.5	20
2SJ304	-60	-14	40	TO-220NIS	0.08	0.12	-10	-7	0.13	0.19	-4	-5	45
2SJ312	-60	-14	40	TO-220FL/SM	0.08	0.12	-10	-7	0.13	0.19	-4	-5	45
2SK1381	100	50	150	TO-3P (N)	0.025	0.032	10	25	0.031	0.046	4	25	88
2SK1382	100	60	200	TO-3P (L)	0.015	0.02	10	30	0.02	0.029	4	30	176
2SK1486	300	32	200	TO-3P (L)	0.08	0.095	10	16	—	—	—	—	140
2SK1544	500	25	200	TO-3P (L)	0.15	0.2	10	13	—	—	—	—	150
2SK1119	1000	4	100	TO-220AB	3	3.8	10	2	—	—	—	—	60
2SK1930	1000	4	80	TO-220FL/SM	3	3.8	10	2	—	—	—	—	60
2SK1359	1000	5	125	TO-3P (N)	3	3.8	10	2	—	—	—	—	60
2SK1365	1000	7	90	TO-3P (N) IS	1.5	1.8	10	4	—	—	—	—	120
2SK1120	1000	8	150	TO-3P (N)	1.5	1.8	10	4	—	—	—	—	120
2SK1489	1000	12	200	TO-3P (L)	0.8	1	10	6	—	—	—	—	110

○  $\pi$ -MOS V (V<sub>DSS</sub> = 200 V series)

The V<sub>DSS</sub> of 180 to 200 V series is ideal solutions for power amp applications such as audio amps.

- N-channel and P-channel complementary
- Wide package selection from PW-MOLD to TO-3P (L)

Part Number	V <sub>DSS</sub> (V)	I <sub>D</sub> (A)	P <sub>D</sub> (W)	Package	R <sub>DS (ON)</sub> ( $\Omega$ )				Y <sub>fs</sub>		
					Typ.	Max	V <sub>GS</sub> (V)	I <sub>D</sub> (A)	Typ.	V <sub>DS</sub> (V)	I <sub>D</sub> (A)
2SK2013	180	1	25	TO-220NIS	2.8	5	10	0.6	0.7	10	0.3
2SK2162	180	1	20	PW-MOLD	2.8	5	10	0.6	0.7	10	0.3
2SK2467	180	9	80	TO-3P (N) IS	0.42	0.83	10	6	4	10	3
2SK1529	180	10	120	TO-3P (N)	0.42	0.83	10	6	4	10	3
2SK3497	180	10	130	TO-3P (N)	0.09	0.15	7	5	12	10	5
2SK1530	200	12	150	TO-3P (L)	0.31	0.625	10	8	5	10	5
2SJ313	-180	-1	25	TO-220NIS	2	5	-10	-0.6	0.7	-10	-0.3
2SJ338	-180	-1	20	PW-MOLD	2	5	-10	-0.6	0.7	-10	-0.3
2SJ440	-180	-9	80	TO-3P (N) IS	0.25	0.83	-10	-6	4	-10	-3
2SJ200	-180	-10	120	TO-3P (N)	0.25	0.83	-10	-6	4	-10	-3
2SJ618	-180	-10	130	TO-3P (N)	0.24	0.37	-7	-5	12	-10	-5
2SJ201	-200	-12	150	TO-3P (L)	0.25	0.625	-10	-8	5	-10	-5

Applications	Part Number	Maximum Ratings			R <sub>DS (ON)</sub> (mΩ)				V <sub>th</sub> (V) (I <sub>D</sub> = 1 mA)
		V <sub>DSS</sub> (V)	I <sub>D</sub> (A)	P <sub>D</sub> (W)	R <sub>DS (ON)</sub> (mΩ)		V <sub>GS</sub> (V)	I <sub>D</sub> (A)	
					Typ.	Max			
DC-DC Converters, Motherboards, Automotive equipment	2SJ619	-100	-16	75	150	210	-10	-6	-0.8~-2.0
					250	320	-4	-6	
	2SJ620	-100	-18	125	64	90	-10	-9	-0.8~-2.0
					85	120	-4	-9	
	2SK3397	30	70	125	4	6	10	35	1.5~3.0
	2SK3389	30	75	125	3.8	5	10	38	2.0~4.0
	2SK3439	30	75	125	3.8	5	10	38	1.3~2.5
					5.0	10	4	38	
	2SK3440	60	50	125	6.5	8	10	25	2.0~4.0
	2SK3441	60	75	125	4.5	5.8	10	38	1.3~2.5
					5.8	10	4	28	
	2SK3442	100	45	125	15	20	10	23	2.0~4.0
	2SK3387	150	18	100	80	120	10	9	0.8~2.0
					90	180	4	9	
	2SK3443	150	30	125	50	55	10	15	3.0~5.0
	2SK3444	200	25	125	65	82	10	12.5	3.0~5.0
	2SK3388	250	20	125	82	105	10	10	2.0~4.0
	2SK3445	250	20	125	90	105	10	10	3.0~5.0
	2SK3499	400	8.5	80	400	550	10	5	2.0~4.0
	2SK3544	450	13	100	290	400	10	6.5	2.0~4.0
2SK3466	500	5	50	1350	1500	10	2.5	2.0~4.0	
2SK3398	500	12	125	400	520	10	6	2.0~4.0	
2SK3438	600	10	125	740	1000	10	5	3.0~5.0	
2SK3538	500	8	65	750	850	10	4	2.0~4.0	